



DVM179

Quick Start Guide

Multimedia Receiver with Bluetooth featuring a 7" digital touch screen TFT



This Quick Start Guide gives you the basics to start using your DVM179

Please visit www.dualav.com/support/manuals.php to download a complete owner's manual, or call customer service at

1-866-382-5476
(Monday-Friday, 9AM-5PM EST)

Installation

Tools Required

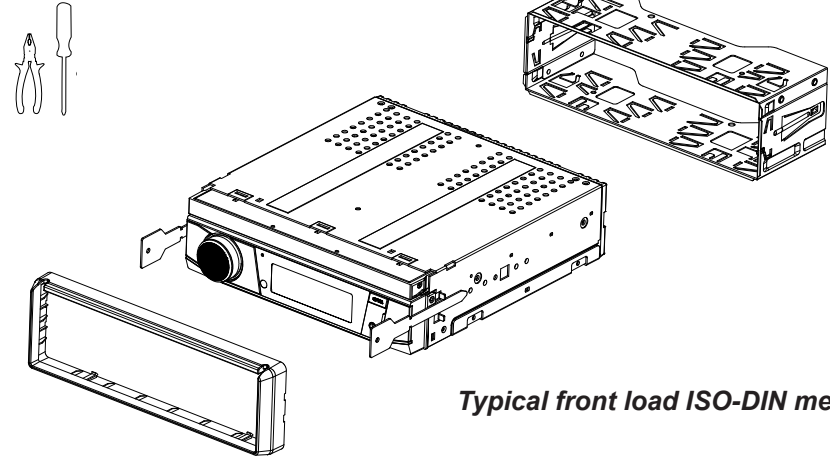

Typical front load ISO-DIN method

Wiring Diagram - Input / Outputs

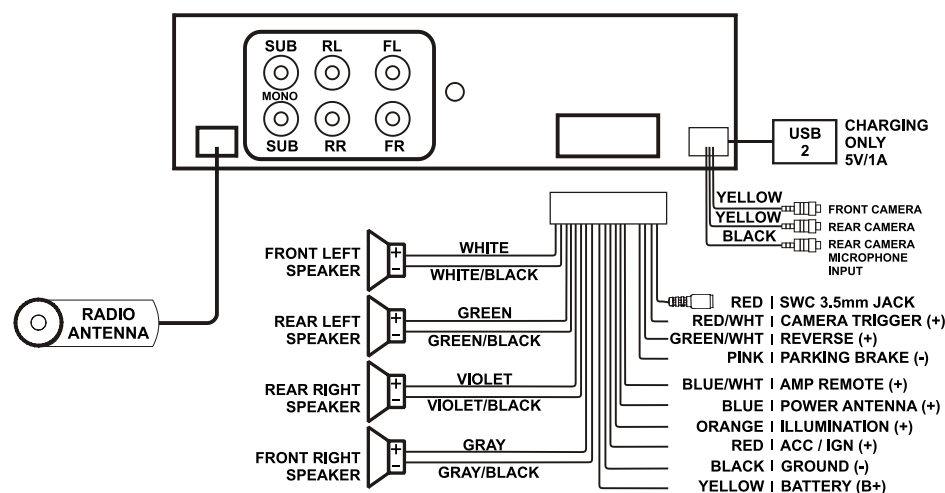

Copyright and Trademark Notes
SD Logo is a trademark of SD-3C, LLC.
Other trademarks and trade names are those of their respective owners.

Control Panel



1. Power / Source Mode
2. Play / Pause
3. Rotary Volume Up/Down
4. Mute - Short Press Rotary
5. Tune/Track Up / Answer Call
6. Tune/Track Down / End Call
7. BT Microphone
8. LCD Display
9. Open TFT - Press to open/close
10. 3.5mm AUX IN
11. USB Media Port / Charging Port
12. microSD Media Port
13. Reset

IR Remote Control

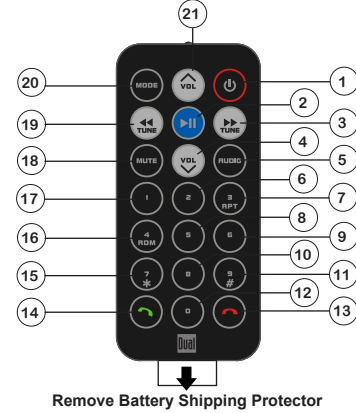

1. Power
2. Play/Pause / Ok
3. Seek Up / Next Track
4. Volume Down
5. Audio
6. Dial 2
7. Dial 3 / Song Repeat
8. Dial 5
9. Dial 6
10. Dial 8
11. Dial 9 #

How to Replace the Battery

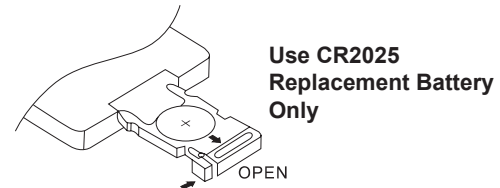

Slide the tray out on back of the remote control and insert battery with the (+) and minus (-) poles pointing in the proper direction

12. Dial 0
13. End call
14. Answer Call / Last Number Redial
15. Dial 7 *
16. Dial 4 / Random
17. Dial 1
18. Mute
19. Seek Down / Previous Track
20. Source Mode
21. Volume UP

Safety Notice

Video / movie playback will not operate while the vehicle is moving. This is a safety feature to prevent driver distraction. In-dash video / movie functions will only operate when vehicle is in Park and the parking brake is engaged. It is illegal in most jurisdictions for the driver to view video while the vehicle is in motion.

SAFETY NOTICE

Watching video while driving is against Federal, State and Local laws

Drive safely, know and obey traffic rules. Watching this screen and making selections while driving can lead to a serious accident. Check surroundings for safety while camera images are displayed.

AGREE

Do not use features of this product while driving if it cannot be operated safely and legally in your location. Before operation of smartphone apps accessible from this device, read safety instructions in your Owner's Manual. When using navigation apps stay alert to observe real world conditions. By pressing "AGREE" button, you have confirmed that you have fully read, understand and accepted these usage terms and conditions.

Main Menu

Press the Top Left Source icon to enter Main Source Menu
In the Menu mode, press the desired icon to enter the desired mode:

1. Radio Direct
2. Media Player Last Source
3. BT Handsfree Direct
4. USB Direct
5. microSD Card Direct
6. BT Streaming Direct
7. AUX IN Direct
8. Rear/Front Camera
9. Main System Setup Menu

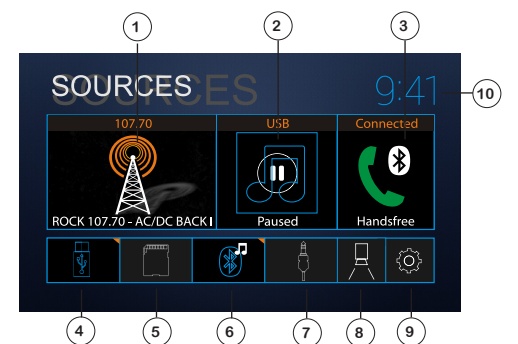

10. Press Clock to Standby Monitor - Press screen anywhere to return - Audio will still continue to play while in Standby mode

Tuner Operation

Select the Tuner icon from the Main Menu screen

1. Current Mode Icon / Main Source Menu
2. Tuner Presets - Long press to set
3. AM Direct
4. FM Direct
5. BT Handsfree Direct
6. Stereo / Mono
7. AS/PS - Auto Scan / Preset Scan
8. Direct Station Entry
9. Station Search
10. EQ Settings
11. Previous Station - Long Press Manual Tune
12. Station Number
13. Next Station - Long Press Manual Tune
14. Station RDS RT Information Title
15. RDS Information Alert
16. Quick BAND Select - FM 1-2-3 | AM 1-2
17. Radio RDS Setup Menu
18. Monitor Standby
19. Loc/DX



Media Player Operation

USB/SD Media operation will work the same way

1. Current Mode / Main Source Menu
2. BT Streaming Music Direct
3. USB Media Direct
4. SD Media Direct
5. BT Handsfree Direct
6. Shuffle On / Off
7. Repeat 1 | All | Off
8. Direct File Entry
9. Drive File List
10. EQ Settings
11. Track Down
12. Play/Pause
13. Track Up
14. Track Time / Status Bar
15. File Playing - ID3 Metadata
16. File Playing - Album Art
17. Track Counter of Folder
18. Press Clock to Standby Monitor

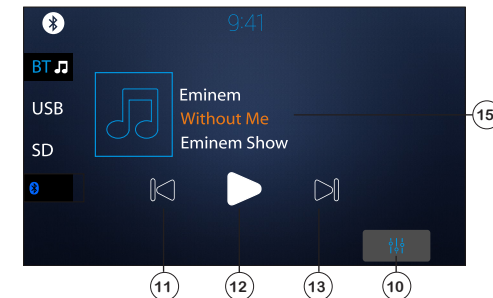
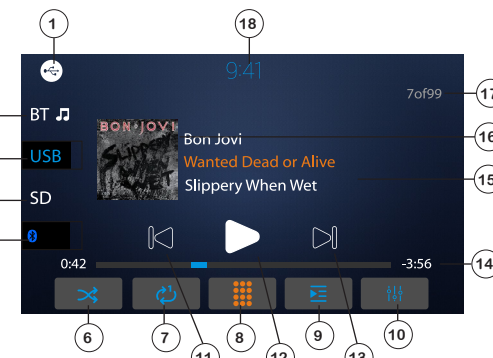

- BT Streaming Media operation
11. Track Down
12. Play/Pause
13. Track Up

Handfree Operation

Bluetooth Microphone - The microphone is built-in to the receiver.

- To ensure the best conversation quality/performance, stay within 3 feet (1 meter) of the unit's microphone when talking.

Pairing and Connecting

- Before using Bluetooth functions, you must pair your mobile phone to the DVM179 unit. The device name is "DUAL BT". The Bluetooth passcode "0000". To ensure the best reception for pairing and re-connection, please make sure the mobile phone battery is fully charged before you begin.
- Try to perform pairing within a few minutes of the mobile phone being turned on.
- Once the unit has been paired with the mobile phone, the unit's model number, "DUAL BT", will be displayed on the mobile phone.
- To achieve the best performance, always keep the mobile phone within 10 feet (3 meters) of the unit.
- Always keep a clear path between the mobile phone and the unit. Never place a metal object or any other obstacle between the mobile phone and the unit.
- Some mobile phones may have a "Power Saving Mode" option. PLEASE DO NOT use the power saving mode with the DUAL BT.
- Before accepting or making a call, make sure your mobile phone's "Bluetooth function" is turned on.

- Dialing a Number**
Press keypad to dial a number.

- Making a Call**
Dial number, press to connect a call

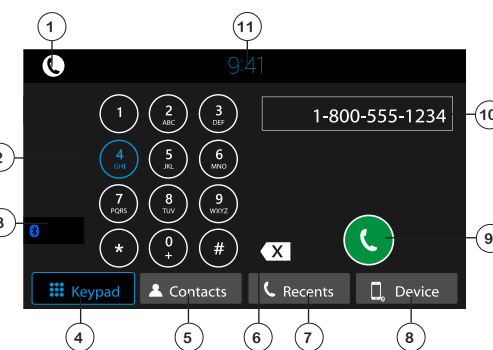

1. Current Mode / Main Source Menu
2. Dial Keypad
3. Back to Last Source
4. BT Keypad
5. Contacts - must be manually synced
6. Backspace
7. Recent Calls
8. Device Manager
9. Call Button
10. Number
11. Press Clock to Standby Monitor - Press screen anywhere to return - Audio will still continue to play while in Standby

- Transferring Audio**
Press to transfer call audio between the headunit and mobile phone

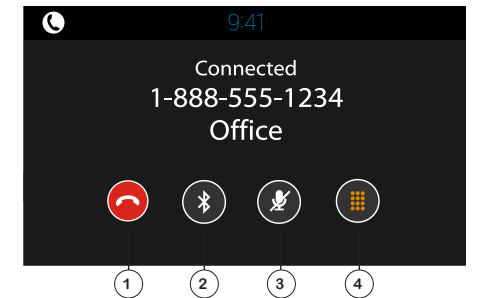

1. Hang Up
2. Call Transfer
3. MIC Mute
4. Return to Keypad

EQ Operation

Press EQ icon in each Source to select EQ settings

Source Tone Memory - Each Source will remember their EQ settings

1. Main System Volume
2. EQ Settings
3. EQ On/Off
4. Loudness On/Off
5. EQ Reset
6. Back to Source
7. EQ Presets / Custom
8. Balance / Fader

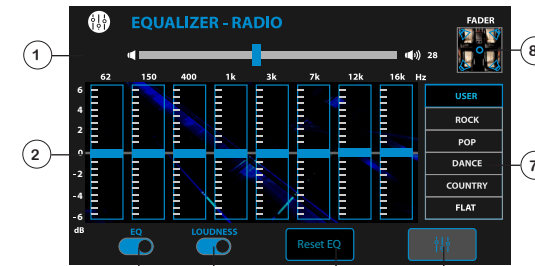

Subwoofer Frequency, Fader and Balance controls do not have Source Tone Memory.

1. Main Volume
2. Fader/Balance
3. Fader Reset
4. Return to Source
5. Subwoofer Controls
6. Return to EQ Controls

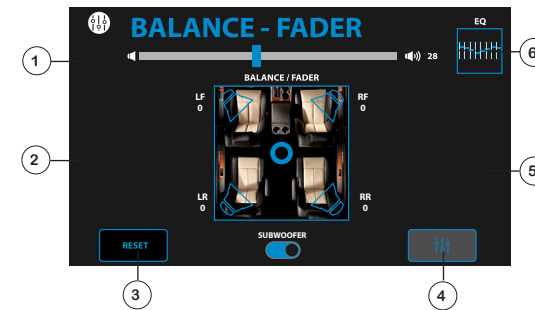

System Settings

Press GEAR icon in MAIN Source Menu

1. Back to Main Menu
2. General Setup
3. Clock Settings
4. System Audio
5. Bluetooth
6. Display - RGB LED, TFT
7. About - Software Version

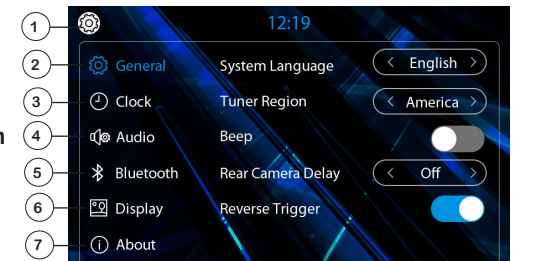

One-Year Limited Warranty

This warranty gives you specific legal rights. You may also have other rights which vary from state to state. Dual Electronics Corp. warrants this product to the original purchaser to be free from defects in material and workmanship for a period of one year from the date of the original purchase.

Dual Electronics Corp. agrees, at our option, during the warranty period, to repair any defect in material or workmanship or to furnish an equal new, renewed or comparable product (whichever is deemed necessary) in exchange without charges, subject to verification of the defect or malfunction and proof of the date of purchase. Subsequent replacement products are warranted for the balance of the original warranty period.

Who is covered? This warranty is extended to the original retail purchaser for products purchased from an authorized Dual dealer and used in the U.S.A.

What is covered? This warranty covers all defects in material and workmanship in this product. The following are not covered: software, installation/removal costs, damage resulting from accident, misuse, abuse, neglect, product modification, improper installation, incorrect line voltage, unauthorized repair or failure to follow instructions supplied with the product, or damage occurring during return shipment of the product. Specific license conditions and copyright notices for the software can be found via www.dualav.com.

What to do? 1. Before you call for service, check the troubleshooting guide in your owner's manual. A slight adjustment of any custom controls may save you a service call. 2. If you require service during the warranty period, you must carefully pack the product (preferably in the original package) and ship it by prepaid transportation with a copy of the original receipt from the retailer to an authorized service center. 3. Please describe your problem in writing and include your name, a return UPS shipping address (P.O. Box not acceptable), and a daytime phone number with your shipment. 4. For more information and for the location of the nearest authorized service center please contact us by one of the following methods:

• Call us toll-free at **1-866-382-5476** (Monday-Friday, 9:00 a.m. to 5:00 p.m. EST)

• E-mail us at cs@dualav.com

Exclusion of Certain Damages: This warranty is exclusive and in lieu of any and all other warranties, expressed or implied, including without limitation the implied warranties of merchantability and fitness for a particular purpose and any obligation, liability, right, claim or remedy in contract or tort, whether or not arising from the company's negligence, actual or imputed. No person or representative is authorized to assume for the company any other liability in connection with the sale of this product. In no event shall the company be liable for indirect, incidental or consequential damages.

FCC Compliance

This device complies with Part 15 of the FCC Rules. Operation is subject to the following two conditions: (1) this device may not cause harmful interference, and (2) this device must accept any interference received, including interference that may cause undesired operation. Warning: Changes or modifications to this unit not expressly approved by the party responsible for compliance could void the user's authority to operate the equipment. Note: This equipment has been tested and found to comply with the limits for a Class B digital device, pursuant to Part 15 of the FCC Rules. These limits are designed to provide reasonable protection against harmful interference in a residential installation. This equipment generates, uses, and can radiate radio frequency energy and, if not installed and used in accordance with the instructions, may cause harmful interference to radio communications. However, there is no guarantee that interference will not occur in a particular installation. If this equipment does cause harmful interference to radio or television reception, which can be determined by turning the equipment off and on, the user is encouraged to try to correct the interference by one or more of the following measures:

- Reorient or relocate the receiving antenna.
- Increase the separation between the equipment and receiver.
- Connect the equipment into an outlet on a circuit different from that to which the receiver is connected.
- Consult the dealer or an experienced radio/TV technician for help.

Exclusion of Certain Damages: This warranty is exclusive and in lieu of any and all other warranties, expressed or implied, including without limitation the implied warranties of merchantability and fitness for a particular purpose and any obligation, liability, right, claim or remedy in contract or tort, whether or not arising from the company's negligence, actual or imputed. No person or representative is authorized to assume for the company any other liability in connection with the sale of this product. In no event shall the company be liable for indirect, incidental or consequential damages.